



Equipos para la construcción

Ficha Técnica Del Producto

HORQUILLAS PARA GRUA

Horquilla a compás

MBA / MB

Regulación práctica hasta la apertura deseada.

Bloqueo de cierre funcional y manejable mediante una manivela especial.



Dimensiones reducidas de espacio y siempre inferiores a la carga llevada.

Horquilla con balance automático con muelle.

Disponibile con dientes 1200 mm



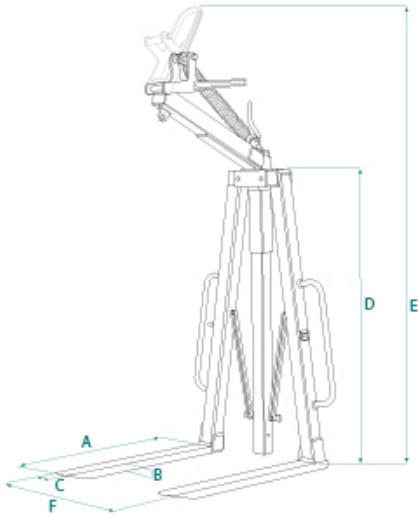

MODELO	CAPACIDAD DE CARGA (kg)	DIMENSIÓN (mm)						PESO (kg)
		A	B	C	D	E	F	
MBA-06	600	1000	25	80	1300	2400	400-1600	95
MBA-10	1000	1000	25	90	1300	2400	400-1600	100
MBA-15	1500	1000	30	90	1300	2400	400-1600	115
MBA-20	2000	1000	35	100	1300	2400	400-1600	140
MBA-25	2500	1000	40	90	1300	2400	400-1600	165
MBA-30	3000	1000	35	120	1300	2400	400-1600	175

MODELO	CAPACIDAD DE CARGA (kg)	DIMENSIÓN (mm)						PESO (kg)
		A	B	C	D	E	F	
MB-06	600	1000	25	80	1100	2200	340-1400	90
MB-10	1000	1000	25	90	1100	2200	340-1400	95
MB-15	1500	1000	30	90	1100	2200	340-1400	110
MB-20	2000	1000	35	100	1100	2200	340-1400	125



Boscaro srl
Via G. Cederle, 1 - 36020
Campiglia dei Berici (Vicenza) Italy

Tel +39 0444 866520
Fax +39 0444 866350
P.IVA: 00672450244