

Truck Mod Customization Catalog



Truck Mod Customization

In the boom truck industry, its not just the crane that's important. Customers often need engineered solutions to ensure that their truck and crane are the perfect match and are field ready when they leave the factory. The Truck Modification Center offers engineered and tested solutions to meet your custom up-fitting needs.

The following catalog lists various customizations related to the overall boom truck package in a one-stop location for your convenience. All these items can be selected during the quoting process and corresponding lead times provided.

The National Crane application engineers staffing the Truck Mod Center recognizes that no two customizations are the same. With that in mind, our team will work very hard to help you configure your truck modifications to meet your individual application requirements, making your National Crane Boom Truck the best tool for the job ready to go from Day 1.

If you wish to discuss an item shown in this guide, a possible variation of one of the listed modifications, or a new customized application based on your needs, please contact National Crane product management or your regional business manager for additional information.



Contents

	Page
Tool Box Options	4
Pintle Hitch Options	6
Heavy Duty SFO Bracket Options / Requirements	13
Outrigger Mats And Storage Rack Options	15
Truck Lift Axle Adds / Wheelbase Modifications Options	19
Electrical Options	21



Tool Box Options

Steel Tool Boxes

Black Powder Coat 14 gauge mild steel tool box with single, drop down door and stainless steel T-handle lock.

Sizes Available: 24 in, 36 in and 48 in Lengths
Boxes are 24 in height and 24 in depth.



Additional Information:

- Available on all National Crane models. Inquire with Truck Mod Center for potential layouts and space availability.
- Tool box pricing is based on factory mounting. A deduct for shipout kits can be applied. See Pricelist for details.

Tool Box Options

Aluminum Tool Boxes

1/8" Aluminum body tool box with Diamond Plate single, drop down door and stainless steel T-handle lock.

Sizes Available: 24 in, 36 in and 48 in Lengths
Boxes are 24 in height and 24 in depth.

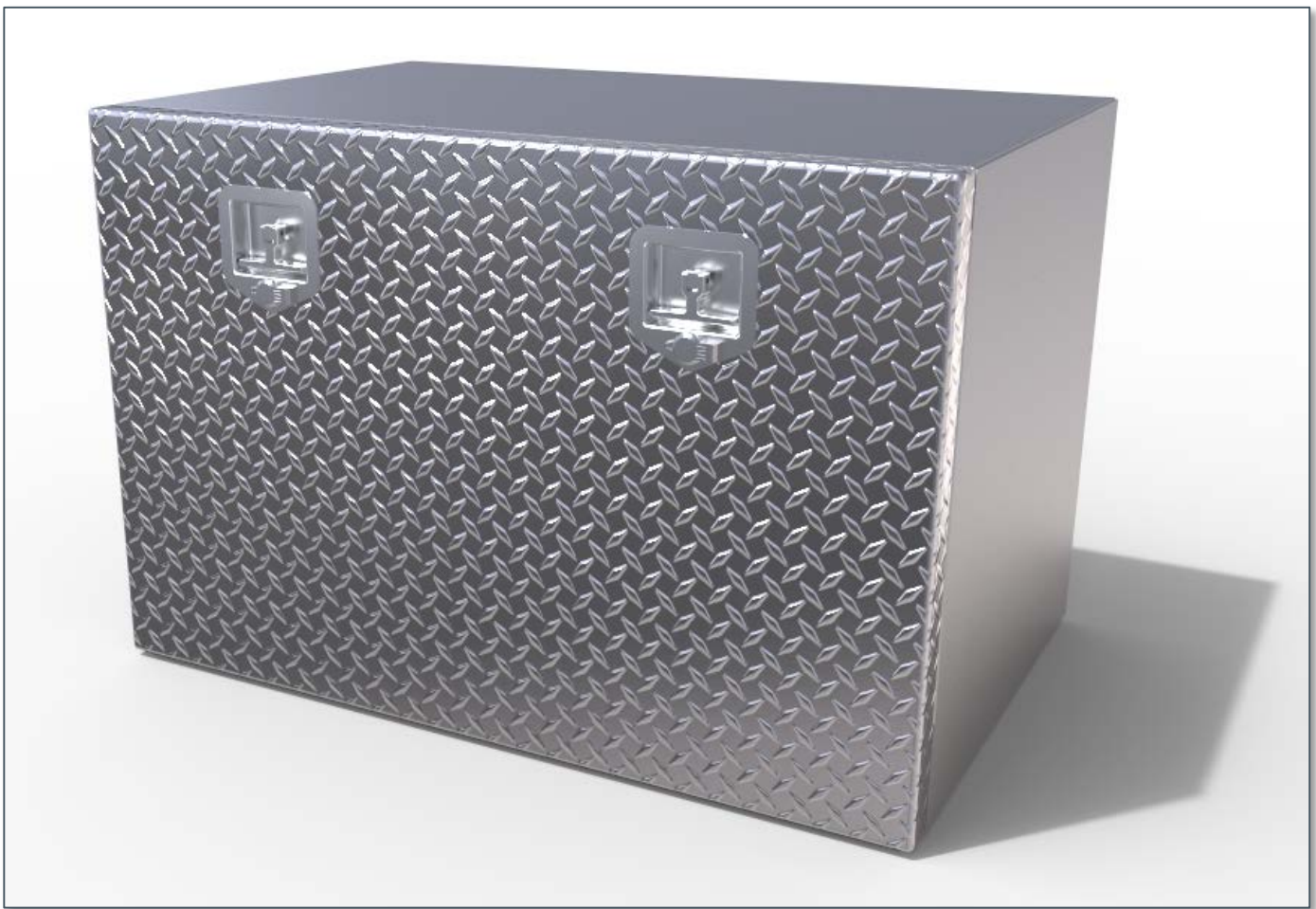

Additional Information:

- Available on all National Crane models. Inquire with Truck Mod Center for potential layouts and space availability.
- Tool box pricing is based on factory mounting. A deduct for shipout kits can be applied. See Pricelist for details.

Pintle Hitch Options

	Page
15 ton Pintle Hitches for Stand Up Models	7
30 ton Pintle Hitches for Stand Up Models	8
30 ton Pintle Hitch for 1300A	9
30 ton Pintle Hitch for 1400A	10
30 ton Pintle Hitch for NBT40-1 Series, NBT50 Series and NBT60	11
15 ton Pintle Hitch for Tractor Mounted Cranes	12



Pintle Hitch Options - Stand Up Models

15 ton Pintle Hitch

This option offers a 15 ton pintle hitch integrated in the truck chassis frame for a rigid mounted connection. There is 7" of vertical tongue adjustment.



Additional Features:

- Integrated LED rear taillights and marker lights.
- Trailer electric and air connections integrated in pintle plate for ease of access.

Pintle Hitch Options - Stand Up Models

30 ton Pintle Hitches

This option offers a 30 ton pintle hitch integrated in the truck chassis frame for a rigid mounted connection. There is 7" of vertical tongue adjustment.

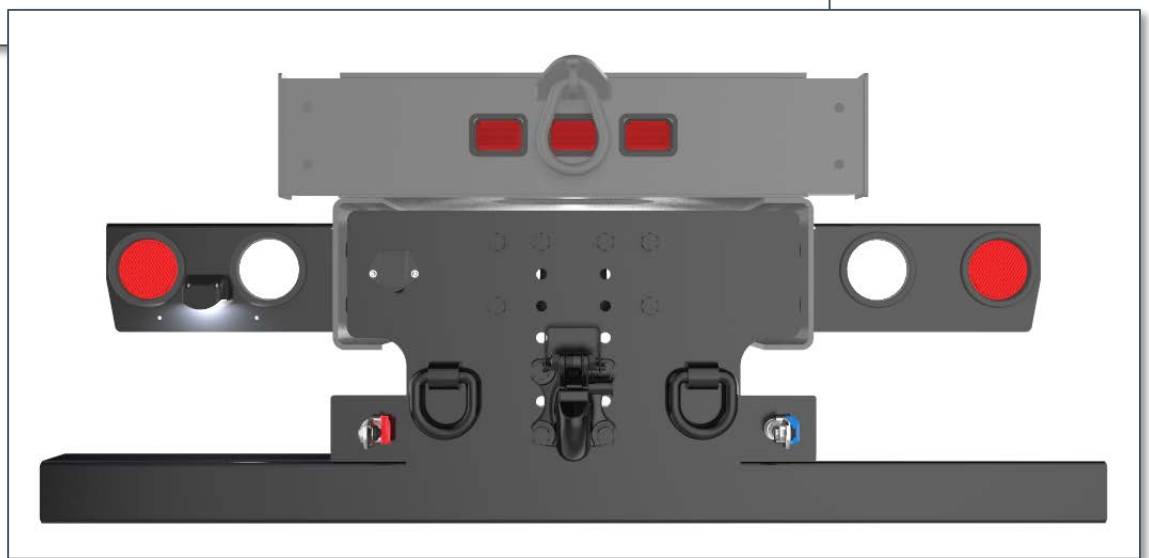

Additional Features:

- Integrated LED rear taillights and marker lights.
- Trailer electric and air connections integrated in pintle plate for ease of access.

Pintle Hitch Options – 1300A

30 ton Pintle Hitch for 1300A

This option offers a 30 ton pintle hitch integrated in the truck chassis frame for a rigid mounted connection. This pintle hitch system offers 7" of vertical adjustment for varying trailer setups.

Pictures Coming Soon!

Additional Features:

- Integrated LED rear taillights and marker lights.
- Integrated trailer electrical connection and glad hands.
- Integrated rear machine access.

Pintle Hitch Options – 1400A

30 ton Pintle Hitch for 1400A

This option offers a 30 ton pintle hitch integrated in the truck chassis frame for a rigid mounted connection. This pintle hitch system offers 7" of vertical adjustment for varying trailer setups.

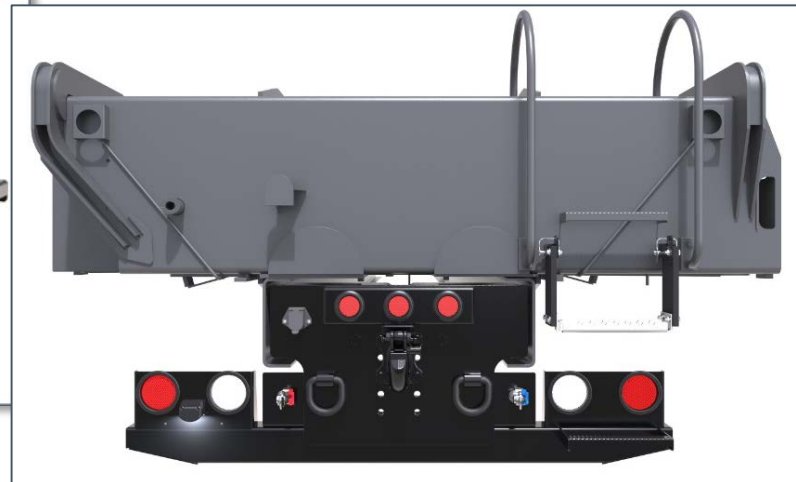
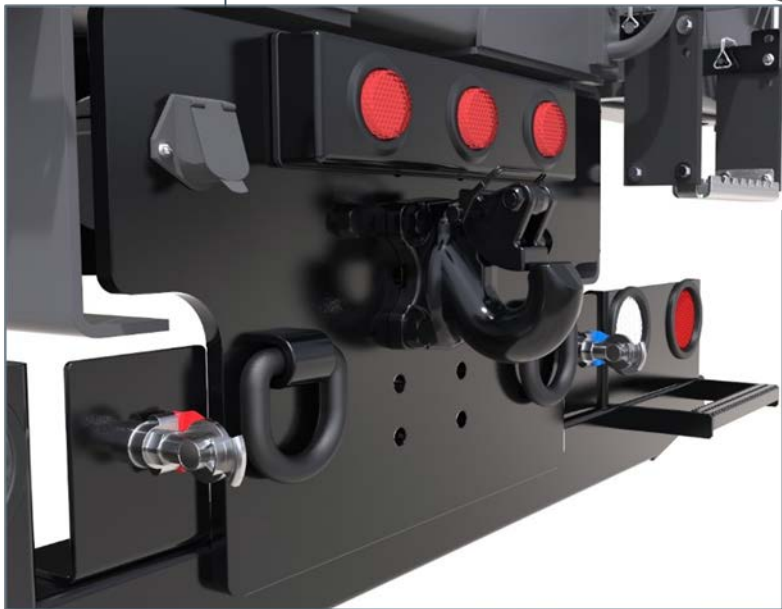

Additional Features:

- Integrated LED rear taillights and marker lights.
- Integrated trailer electrical connection and glad hands.
- Integrated rear machine access.

Pintle Hitch Options – NBT40-1 Series, NBT50 Series and NBT60

30 ton Pintle Hitch for NBT40-1 Series, NBT50 Series and NBT60.

This option offers a 30 ton pintle hitch integrated in the truck chassis frame for a rigid mounted connection. This pintle hitch system offers 7" of vertical adjustment for varying trailer setups.

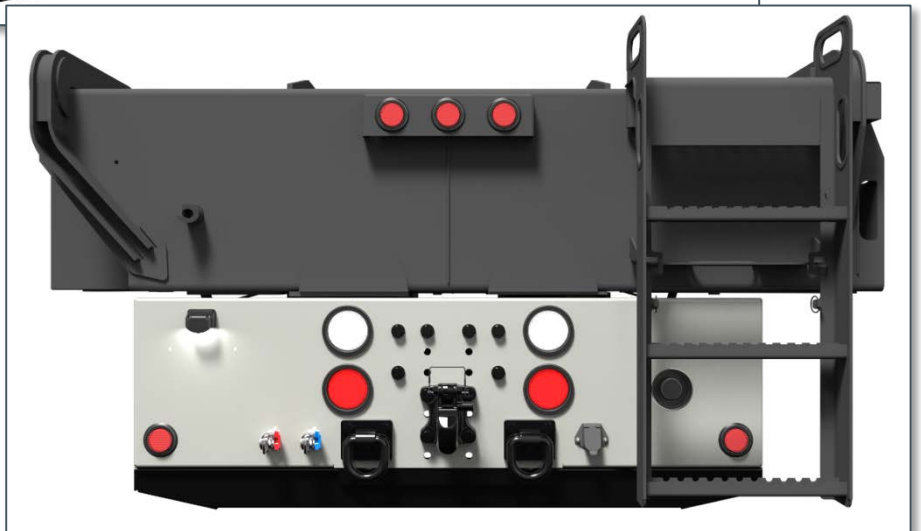

Additional Features:

- Integrated LED rear taillights and marker lights.
- Integrated trailer electrical connection and glad hands.
- Unobstructed rear machine access.

Pintle Hitch Options – Tractor Mounted Cranes

15 ton Pintle Hitch for Tractor Mounted Cranes

This option offers a 15 ton pintle hitch integrated in the truck chassis frame designed for tractor mount tapered frame rails in mind. This pintle hitch system has a fixed vertical position.

Pictures Coming Soon!

Additional Features:

- Integrated LED rear taillights and marker lights.
- Integrated trailer electrical connection and glad hands.

Heavy Duty SFO Requirements

What are Heavy Duty SFO Brackets?

SFO brackets specifically designed for various truck models and configurations due to engine packaging changes where full integral frame material or front frame extensions are not available.

Why are Heavy Duty SFO Brackets important?

These brackets provide sturdy, secure SFO mounting in accordance with the manufacturer's allowable front end vertical load ratings. Because these brackets do not mount to the cast material bumper brackets, there are no fatigue concerns or potential for truck damage due to SFO loading.

When are Heavy Duty SFO Brackets required?

The chart below outlines when the Heavy Duty SFO brackets are needed for each crane model and truck configuration. It is preferred to specify truck with front frame extensions where available to eliminate need for HD SFO brackets.

		Crane Model - Stand Up					Crane Model - Swing Cab				
		800D	800DU	900A	NBT30H-2	1400H	1300A	1400A	NBT36-1	NBT40-1	NBT45-1
Truck Model	Peterbilt 348	X	X	X	X	X			N/A	N/A	N/A
	Peterbilt 365/367/567 SBFA				X	X					
	Peterbilt 367 SFFA / 567 121" BBC SFFA	X	X	X	X	X	X	X	X	X	X
	Peterbilt 365 SFFA / 567 115" BBC SFFA	X	X	X	X	X	X	X	X	X	X
	Kenworth T800 / T880				X	X					

X	HD SFO BRACKETS REQUIRED
N/A	NOT A RECOMMENDED TRUCK FOR THE CRANE MODEL

NOTE: All truck models shown are configured without front frame extensions.

Heavy Duty SFO Options

Heavy Duty SFO Brackets by Truck Model

Using the table on the previous page, there is a specially designed heavy duty SFO bracket for various truck models. The list below is the selection code corresponding with the Truck Mod Customization Price List option to help identify the correct option for your chassis.

CODE	TRUCK MAKE / MODEL
HDSFOA	Peterbilt 337/348/382
HDSFOB	Peterbilt 365/367/567 SBFA
HDSFOC	Peterbilt 367 SFFA or 567 121" BBC SFFA
HDSFOD	Kenworth T800/T880
HDSFOE	Peterbilt 365 SFFA or 567 115" BBC SFFA



Additional Information:

- Heavy Duty SFO mounting charges and lead times are available in the Truck Mod Customization Price List.
- Please contact National Crane product management or your regional business manager regarding questions about necessity of heavy duty SFO brackets.

Outrigger Mats and Storage Rack Options

	Page
CB31 – Polymeric Outrigger Cribbing Mats – 31" x 31"	16
CB36 – Polymeric Outrigger Cribbing Mats – 36" x 36"	16
CBSTOW – Polymeric Outrigger Cribbing Mat Storage Rack	17
PPSP – Personnel Platform Storage Rack	18



Outrigger Mats and Storage Rack Options

Polymeric Outrigger Cribbing Mat

Lightweight mats are a fraction of the weight of an aluminum pad or steel cribbing. Mats can handle up to 3000 psi of compressive load and resist warping, splinter and cracking under normal conditions. Mats have no scrap value!



Additional Information:

- Selection code CB31 for 31" x 31" square pads
- Selection code CB36 for 36" x 36" square pads
- Mat thickness is 1.5" thick.
- Mats never rust or corrode and resist warping, splintering and cracking.

Outrigger Mats and Storage Rack Options

Polymeric Outrigger Cribbing Mat Storage

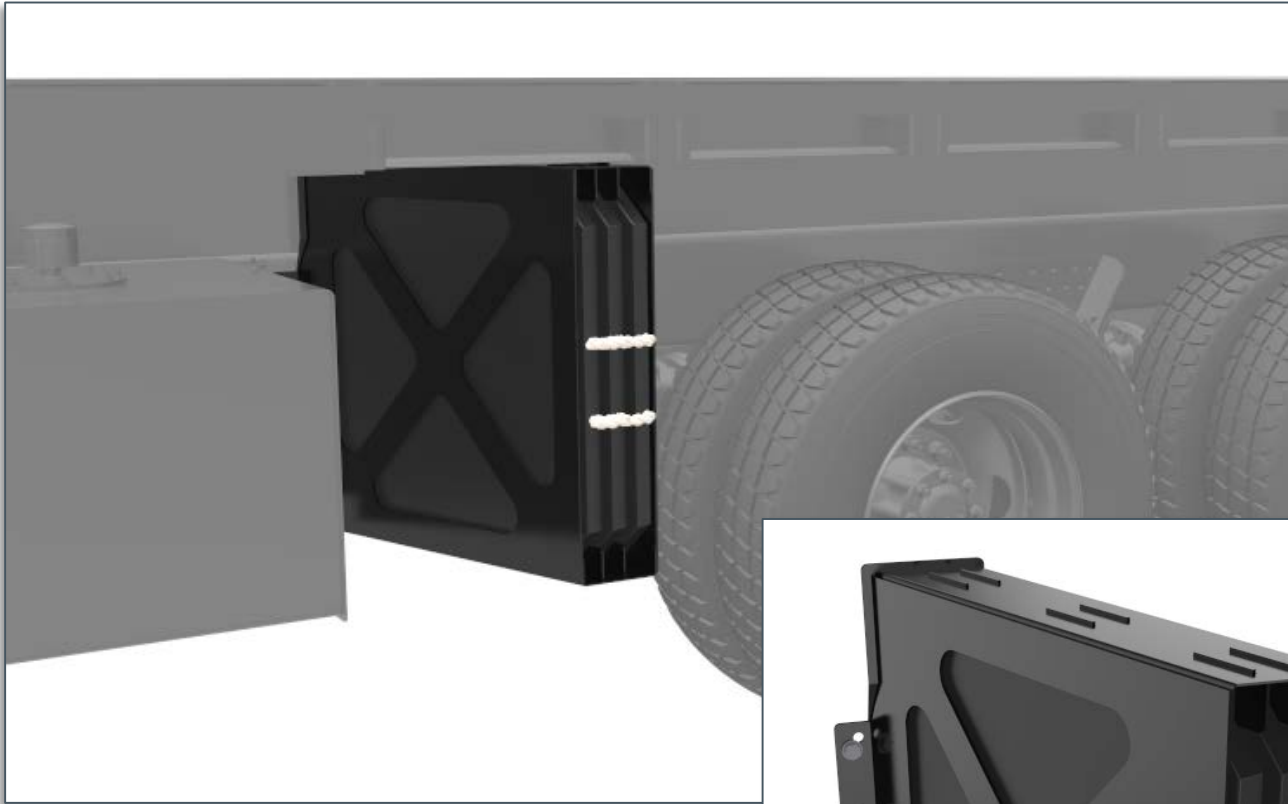

Additional Information:

- Custom Storage designs available through Lift Solutions.
- Have a storage requirement? Please contact National Crane product management or your regional business manager for additional information.

Outrigger Mats and Storage Rack Options

Personnel Platform Storage Rack



Additional Information:

- Available on NBT40-1 Series for use with BSAY-2 and BSAR-1 platform.
- Common application would be in use with the NBT40-1 Series Standard length torsion box for easy storage and retrieval of the platform at the jobsite.

Truck Lift Axle Adds

Pusher and Tag Axle additions

Need to distribute the crane weight or intended payload around on the chassis? National Crane Truck Mod Center can help by configuring a lift axle of various capacities to meet your application needs. We install 8K, 13.5K and 20K steerable lift axles at your request for not only crane weight distribution but also if your application needs the greater payload capacity.

Installation includes control valve integral to the truck chassis when specified or add-on valve for pressure regulation and control. All lift axles lift and lock in reverse and with park brake engaged.



Additional Information:

- 8KLA – 8,000 lb capacity steerable lift axle equipped with 215/75R17.5 tires and aluminum Alcoa wheels.
- 13KLA – 13,500 lb capacity steerable lift axle equipped with 295/75R22.5 tires and aluminum Alcoa wheels.
- 20KLA – 20,000 lb capacity steerable lift axle equipped with 315/80R22.5 tires and aluminum Alcoa wheels.

Wheelbase Modifications Options

Roll Truck Wheelbase to meet your needs.

The National Crane Truck Mod Center can facilitate the wheelbase modification of your chassis to meet what application is needed. Often times trucks are ordered with the correct wheelbase for an application but if there is a truck closely meeting the specifications but a wheelbase needs changed, we can make it the correct length for your application.

Regardless of the application, National Crane Truck Mod Center can handle moving tandem rear axles, tridem rear axles, and lift axles to the best location on the chassis for any application.

Additional Information:

- WBR2 selection code for a wheelbase roll of a tandem rear axle.
- WBR3 selection code for a wheelbase roll of a tridem rear axle or a tandem rear axle with a lift axle already installed.
- See Truck Mod Customization Price List for pricing and lead times.

Electrical Options

Truck Backup Cameras

Add a backup camera to your custom crane mounting! Backup camera mounted on the rear of the machine. Location may vary with crane model.

National Crane can integrate the rear view monitor into the factory navigation screen integrated on the truck interior if option is equipped. Otherwise, an additional rear view monitor will be added to the truck cab interior for rear view viewing.



Additional Information:

Rear view monitoring will not be available in the crane cab. If this is desired, please contact National Crane product management or your regional business manager for additional information.

Contents of this publication are subject to change at any time. The current copy is available on [Manitowoc Direct/Truck Mod Center page](#).



© The Maniowoc Company, Inc.
08/2017

www.maniowoc.com